



swiss bed concept



OAKWILD BORMIO / CORTINA

Wildeiche massiv | chêne noueux massif | solid wildoak



Bettrahmen | cadre de lit | bedframe

Bormio 18



Cortina 18



Breiten | largeurs | widths:
140, 160, 180, 200 cm

Längen | longueurs | lengths:
200, 210, 220 cm

Einlegetiefe | hauteur encastrable | insertion depth:
18 cm



Breiten | largeurs | widths:
140, 160, 180, 200 cm

Längen | longueurs | lengths:
200, 210, 220 cm

Einlegetiefe | hauteur encastrable | insertion depth:
18 cm

Traversen | traverses | bars

Wir empfehlen beim Einsatz von preisgünstigen Lattenrosten oder hoher Gewichtsbelastung eine **Crosstraver** (Quertraverse) oder **Crosstraver-Twin** (Quertraversen) beim Einsatz von Box/Conti. Für Betten ab 160 cm mit 2 Lattenrosten oder für den Motorrahmeneinbau eine **Midtraver** (Längstraverse).

En cas d'intégration d'un sommier premier prix ou de charge importante nous recommandons une **Crosstraver** (traverse transversale) ou **Crosstraver-Twin** (traverses transversales) avec Box/Conti. Pour un cadre de lit à partir de 160 cm avec 2 sommiers ou pour l'encastrement d'un sommier à moteur une **Midtraver** (traverse centrale).

We recommend a **Crosstraver** (central cross bar) for use with budget-priced slats or high weight loads or **Crosstraver-Twin** (cross bars) with Box/Conti. For beds up to 160 cm with 2 slats or motorframes, a **Midtraver** (central bar).

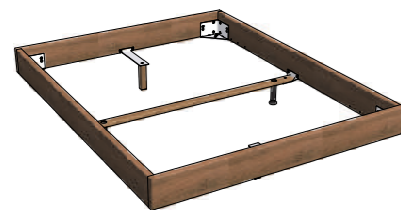

Crosstraver
Quertraverse
Traverse transversale
Central cross bar

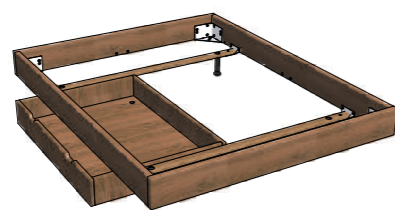

Crosstraver-Twin
Quertraversen
Traverses transversales
Cross bars

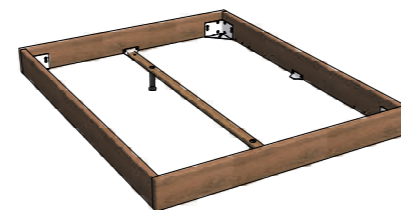

Midtraver
Längstraverse
Traverse centrale
Central bar

Füsse | pieds | feet

Cobo 10



Cobo 20



Cobo 25



Cobo 10



Cobo 20



Cobo 25



	Masse cm dim. cm	Höhen cm hauteurs cm heights cm	Holzfarben couleurs bois colours wood		Masse cm dim. cm	Höhen cm hauteurs cm heights cm	Metallfarben couleurs métal colours metal
Holz bois wood		10 20 25	93 94 98	Metall métal metal		10 20 25	16 43 45
Cobo 10	14,3/14,3/28,6	●	● ● ●	Cobo 10	14,4/14,4/28,7	●	● ● ●
Cobo 20	14,3/14,3/38,6	●	● ● ●	Cobo 20	14,4/14,4/38,7	●	● ● ●
Cobo 25	14,3/14,3/43,6	●	● ● ●	Cobo 25	14,4/14,4/43,7	●	● ● ●

Ausführungen | exécutions | executions

Holz | bois | wood



93 Wildeiche natur, gebürstet, geölt
Chêne nouveau naturel, brossé, huilé
Wildoak natural, brushed, oiled



94 Wildeiche weiss, gebürstet, geölt
Chêne nouveau blanc, brossé, huilé
Wildoak white, brushed, oiled



98 Wildeiche coffee, gebürstet, geölt
Chêne nouveau coffee, brossé, huilé
Wildoak coffee, brushed, oiled

Metall | métal | metal



16 Anthracit



43 Inox



45* Iron

Anthracit = Metall pulverbeschichtet | métal thermolaqué | metal powder-coated
Inox = Edelstahl gebürstet | acier inoxydable brossé | stainless steel brushed
Iron = Metall geflammt, lackiert | métal flammé, laqué | metal mottled, lacquered



*** Unsere Metallfüsse und Griffe in der Ausführung Iron werden bei über 1000° Celsius geschweisst. Die Verfärbungen der Schweissnähte und die Patina verleihen das gewisse Extra und sind gewollt.**
Nos pieds et poignées en métal en exécution Iron sont soudés à plus de 1000° Celsius.
La coloration des soudures ainsi que la patine sont voulues et leurs donnent une touche unique.
Our metal feet and handles in exécution Iron are welded at over 1000° Celsius.
The discolouration of the weld and the patina are intended and gives them that little extra.

Eichenholz ist ein Naturmaterial, das im Laufe der Jahre reift und seinen Charakter ändert. Der deutlich sichtbare Jahresringaufbau verleiht der Eiche eine kräftige, gleichmäßige Struktur. Äste und Markstrahlen im Eichenholz sind völlig natürlich. Diese verleihen Oak-Wild seinen aussergewöhnlichen und markanten Charakter. Die Eiche vermittelt Ruhe, Geborgenheit und Beständigkeit.

Bei der Ausführung Wild wird bewusst mit Rissen und Ästen versehenes Holz verwendet, um den speziellen Wild-Look und Charakter zu erreichen. Farb- und Strukturunterschiede sind bei Echtholz naturbedingte Eigenschaften.

Ein Verzug von 1–2 mm ist bei Naturprodukten unumgänglich und kein Grund zur Beanstandung.

Le bois de chêne est un matériau naturel, qui mûrit et change de caractère au fil des années. Les anneaux de croissance nettement visibles prêtent au chêne une structure puissante et uniforme. Les noeuds et veinures sont tout à fait naturels dans le bois de chêne ce qui donne son caractère exceptionnel à Oak-Wild. Le chêne procure le repos et la continuité.

Pour la version chêne nouveau nous utilisons volontairement du bois fissuré et nouveau afin d'obtenir le look et le caractère de ce matériau. Les différences de couleur et structure sont des particularités naturelles du bois massif.

Une déformation de 1–2 mm des produits naturels est inévitable et n'est pas sujet à réclamation.

Oak wood is a natural material, which changes his character and matures over the years. The clearly visible annual rings gives a strong and uniform structure to the oak. Branches and core radiations in oak are completely natural. These gives Oak-Line his unique and distinctive character. The oak procures peace and durability.

For achieving the special wild look and character, we are using deliberately cracked and branched wood for the wild finish. Differences of colours and structures are natural characters of solid wood.

A distortion of 1–2 mm in natural products is inevitable and is no reason for complaint.

Kopfteile | têtes de lit | headboards



Kopfteil-Verlängerungsadapter siehe Seite 9.60
Réhausseur pour tête de lit voir page 9.60
Extension adapter for headboards see page 9.60



Kopfteile têtes de lit headboards	Holzfarben couleurs bois colours wood		
	93	94	98
Alpa	●	●	●
Areba	●		
Balco	●	●	●
Barro	●	●	●
Inca	●		
Sion	●	●	●

Kissen zu Kopfteilen | coussins pour têtes de lit | cushions for headboards

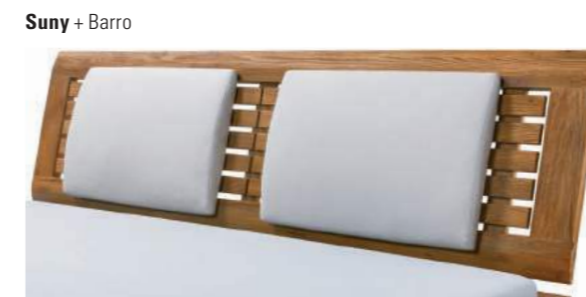

Stoffauswahl/Farben für Kissen siehe Register 1, Seiten 6–7.
Choix de tissus/couleurs pour coussins voir index 1, pages 6–7.
Choice of tissues/colours for cushions see index 1, pages 6–7.

Befestigung mit 2 Bändern (Klettverschluss)
Fixation avec 2 bandes (velcro®)
Fixation with 2 ribbons (Velcro® fastener)

Kissen coussins cushions	Effektive Masse cm dimensions effectives cm effective dimensions cm	zu Kopfteilen pour têtes de lit for headboards					Breitenmasse cm dimensions de largeur cm widths dimensions cm
		Alpa	Areba	Balco/Inca	Barro	Sion	
Arona	86, 116, 136, 156, 176×3,5×25	●					90/100, 120, 140, 160, 180/200
Lumo	86, 116, 136, 156, 176×6×25	●					90/100, 120, 140, 160, 180/200
Nakio*	55×19×14			●			
Ravo	80, 110, 130, 150, 170, 190×3,5×35	●	●			●	90/100, 120, 140, 160, 180, 200
Sano*	55×4×35	●	●			●	
Sema*	55×4×35	●	●			●	
Suny*	55×6×40	●			●	●	

* 2er Set | set de 2 | set of 2

Ausführungen | exécutions | executions

Holz | bois | wood



93 Wildeiche natur, gebürstet, geölt
Chêne nouveau naturel, brossé, huilé
Wildoak natural, brushed, oiled



94 Wildeiche weiss, gebürstet, geölt
Chêne nouveau blanc, brossé, huilé
Wildoak white, brushed, oiled



98 Wildeiche coffee, gebürstet, geölt
Chêne nouveau coffee, brossé, huilé
Wildoak coffee, brushed, oiled

Metall | métal | metal



16 Anthracit

Anthracit = Metall pulverbeschichtet | métal thermolaqué | metal powder-coated
Inox = Edelstahl gebürstet | acier inoxydable brossé | stainless steel brushed
Iron = Metall geflammt, pulverbeschichtet | métal flammé, thermolaqué | metal mottled, powder-coated



43 Inox



45 Iron*

Kopfteile | têtes de lit | headboards

gepolstert | rembourrées | upholstered



Adapter | adaptateur | adapter

Bei hohen Matratzen kann mit dem Verlängerungsadapter das Kopfteil erhöht werden.

La tête de lit peut être rehaussée avec l'adaptateur quand le matelas est plus épais.
With the extension adapter the headboard can be extended if mattresses are high.

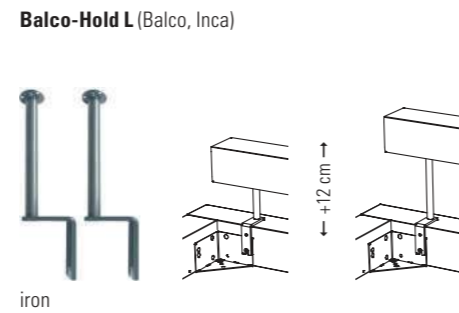
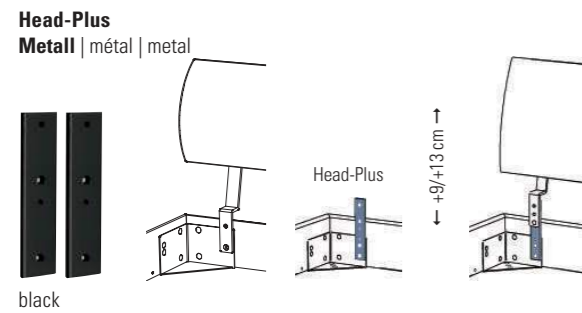

Weitere gepolsterte Kopfteile, Wandpaneele, Stoffauswahl/Farben sowie Lampen siehe Register 1.
Autres têtes de lits rembourrées, panneaux muraux, choix de tissus/couleurs ainsi que lampes voir index 1.
More upholstered headboards, wallpanels, choice of tissues/colours as well as lamps see index 1.

Nachttische, Kommoden | tables de nuit, commodes | bedside tables, chests of drawers

<p>Osta</p>	<p>Cubo</p>	<p>Menza</p>	<p>Cera</p>	<p>Cera + Covo</p>	<p>Cera + Seca</p>
<p>Caja</p>	<p>Carpi</p>	<p>John</p>	<p>Ludo</p>	<p>Ablo alu, chrom, inox</p>	
<p>für Montage am Bett Bormio pour montage au lit Bormio for assembling directly to the bed Bormio</p>	<p>höhenverstellbar réglable en hauteur adjustable in height</p>	<p>höhenverstellbar réglable en hauteur adjustable in height</p>	<p>inkl. Glasplatte plateau en verre inclus incl. glass plate</p>		
<p>Cerina</p>	<p>Cerina + Seca</p>	<p>Cessa</p>	<p>Cessa + Placo</p>		
<p>Griffe, Deko, Glasplatten siehe Seite 9.62 Poignées, déco, plateaux en verre voir page 9.62 Handles, deco, glassplates see page 9.62</p>					

Blumotion



Für unsere Nachttische und Kommoden verwenden wir ausschliesslich den gedämpften Selbsteinzug Blumotion von BLUM.

Pour nos tables de nuit et commodes nous utilisons exclusivement les tiroirs avec système d'amortissement Blumotion de BLUM.

For our bedside tables and chests of drawers we utilize exclusively the silent and soft self closing drawer runner Blumotion of BLUM.

Ausführungen Holz/Metall siehe Seite 9.63 | exécutions bois/métal voir page 9.63 | executions wood/metal see page 9.63

Griffe | poignées | handles



Covo, Cerina und Cessa standardmässig mit Holzgriffen, optional Covo und Seca Griffe.
Cera, Cerina et Cessa standard avec poignées en bois, en option poignées Covo et Seca.
Cera, Cerina and Cessa with wooden handles standard, optional Covo and Seca handles.

Deko | déco | deco



3er Set
set de 3
set of 3

Glasplatten | plateaux en verre | glassplates

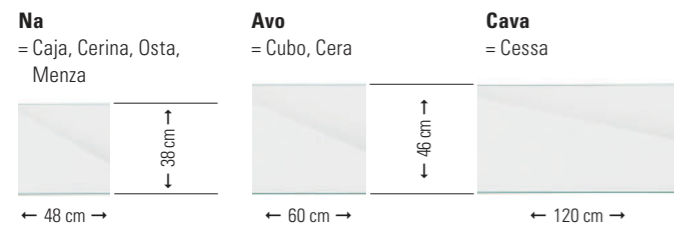

Glas transparent | verre transparent | glass transparent

Zubehör | accessoires | accessories

Bank + Kissen | banquette + coussin | bench + cushion

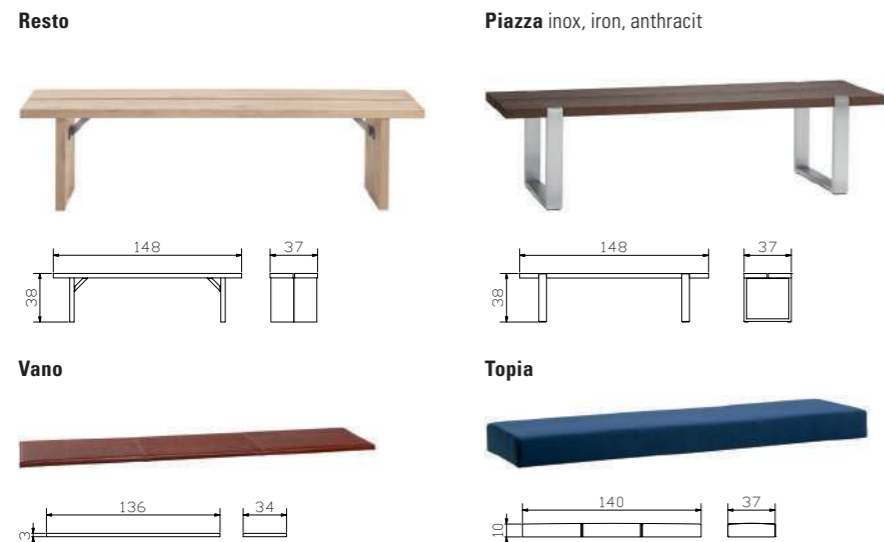

Vano, Topia
Bezugsstoffe siehe Seiten 1.6 – 1.7
Tissus de revêtement voir pages 1.6 – 1.7
Cover fabrics see pages 1.6 – 1.7

Herrendiener | valet | dressboy

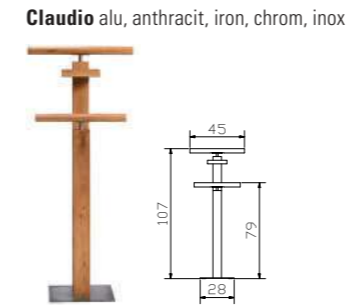

Sekretär | secrétaire | bureau



Bettkasten | coffre à literie | bedding box



Voraussetzungen für Einsatz Conti Bettkasten

Generell
Bettfusshöhe von mindestens 20 cm erforderlich.

Seitlich
Keine Crosstraver, keine Midtraver, nur mit Crosstraver-Twin.

Frontal
Nur bei 140 cm Breite, keine Vilo Füße, keine Crosstraver-Twin, keine Midtraver, nur mit Crosstraver.

Optionen
Deckel Cover nur in weiss, Stoffabdeckung Sacco in Polyester grau.

Conditions d'utilisation d'un coffre à literie Conti

En général
Une hauteur de pieds de lit d'au moins 20 cm est nécessaire.

Insertion latérale
Pas de Crosstraver, pas de Midtraver, uniquement avec Crosstraver-Twin.

Insertion frontale
Uniquement pour largeur 140 cm, pas de pieds Vilo, pas de Crosstraver-Twin, pas de Midtraver, uniquement avec Crosstraver.

Options
Couvercle Cover uniquement en blanc, tissu de protection Sacco en polyester gris.

Requirements for using bedding box Conti

General
Feet of bed need a minimum height of 20 cm.

Laterally
No Crosstraver, no Midtraver, only with Crosstraver-Twin.

Frontal
Only with width 140 cm, no feet Vilo, no Crosstraver-Twin, no Midtraver, only with Crosstraver.

Options
Cover only in white, tissue of protection Sacco in polyester grey.

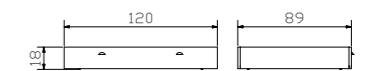

Ausführungen | exécutions | executions

Holz | bois | wood

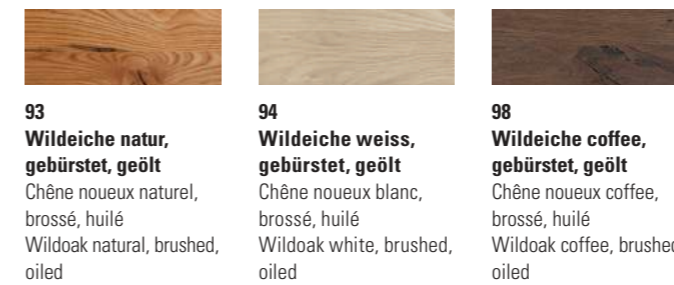

93 Wildeiche natur, gebürstet, geölt
Chêne nouveaux naturel, brossé, huilé
Wildoak natural, brushed, oiled

94 Wildeiche weiss, gebürstet, geölt
Chêne nouveaux blanc, brossé, huilé
Wildoak white, brushed, oiled

98 Wildeiche coffee, gebürstet, geölt
Chêne nouveaux coffee, brossé, huilé
Wildoak coffee, brushed, oiled

Metall | métal | metal

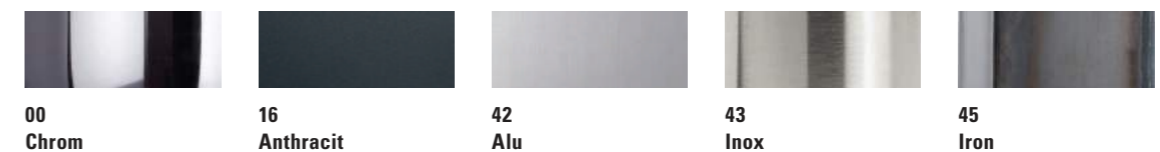

00 Chrom **16 Anthracit** **42 Alu** **43 Inox** **45 Iron**

Chrom = Metall verchromt | métal chromé | metal chrome
Anthracit = Metall pulverbeschichtet | métal thermolaqué | metal powder-coated
Alu = Metall pulverbeschichtet | métal thermolaqué | metal powder-coated
Inox = Edelstahl gebürstet | acier inoxydable brossé | stainless steel brushed
Iron = Metall geflammt, pulverbeschichtet | métal flammé, thermolaqué | metal mottled, powder-coated



				Dimension cm
Cessa	Kommode	commode	chest of drawers	120/48/80
Placo iron	Deko (3er Set)	déco (set de 3)	deco (set of 3)	
Conti	Bettkasten	coffre à literie	bedding box	120/89/18
Cerina	Nachtisch	table de nuit	bedside table	48/43/57
Seca iron	Griffe (3er Set)	poignées (set de 3)	handles (set of 3)	

				Dimension cm
Bormio 18	Rahmen Breiten Längen	cadre largeurs longueurs	frame widths lengths	140, 160, 180, 200 200, 210, 220
Cobo iron	Füße Höhen	pieds hauteurs	feet heights	10, 20, 25
Sion	Kopfteil	tête de lit	headboard	140, 160, 180, 200
Capa iron	Deko	déco	deco	
Sano	Kissen (2er Set) Vintage fango 520	coussins (set de 2) Vintage fango 520	cushions (set of 2) Vintage fango 520	55/4/35

Alle Holzteile in Wildeiche natur, gebürstet, geölt | toutes les parties en bois en chêne nouveau naturel, brossé, huilé | all wooden parts in wildoak natural, brushed, oiled
9.64

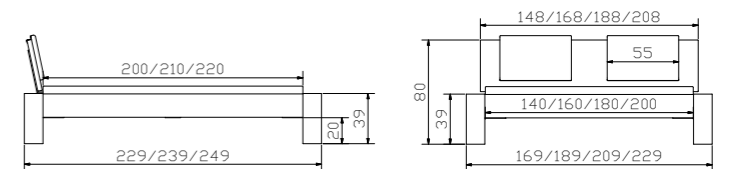



				Dimension cm
Coset	Sekretär	secrétaire	bureau	120/60/86
Vecio	Bank	banquette	bench	110/27/45
Osta	Nachttisch	table de nuit	bedside table	48/38/32

Bei hohen Matratzen kann mit dem Verlängerungsadapter das Kopfteil um 12 cm erhöht werden.

La tête de lit peut être rehaussée de 12 cm avec l'adaptateur quand le matelas est plus épais.
With the extension adapter the headboard can be extended 12 cm if mattresses are high.

Balco-Hold L (Balco, Inca)

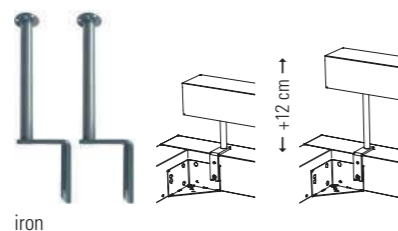

iron

Alle Holzteile in Wildeiche natur, gebürstet, geölt | toutes les parties en bois en chêne naturel, brossé, huilé | all wooden parts in wildoak natural, brushed, oiled
9.66

				Dimension cm
Bormio 18	Rahmen Breiten Längen	cadre largeurs longueurs	frame widths lengths	140, 160, 180, 200 200, 210, 220
Cobo	Füße Höhen	pieds hauteurs	feet heights	10, 20, 25
Balco Nakio	Kopfteil Kissen (2er Set) Casual carbon 334	tête de lit coussins (set de 2) Casual carbon 334	headboard cushions (set of 2) Casual carbon 334	140/160, 180/200 55/19/14

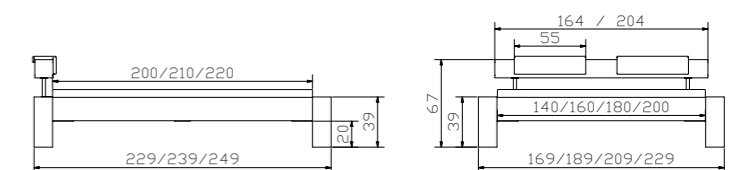

9.67



				Dimension cm
Resto	Bank	banquette	bench	148/37/38
Cera	Nachttisch	table de nuit	bedside table	60/48/38
Smart black	Lampen (2er Set), schwarz 12V DC, 30 LED warm Dreistufenschaltung Energieeffizienzklasse A-A++	lamps (set de 2), noir 12V DC, 30 LED warm interrupteur à 3 crans classe d'efficacité énergétique A-A++	lamps (set of 2), black 12V DC, 30 LED warm three step circuit energy efficiency class A-A++	

				Dimension cm
Bormio 18	Rahmen Breiten Längen	cadre largeurs longueurs	frame widths lengths	140, 160, 180, 200 200, 210, 220
Cobo	Füße Höhen	pieds hauteurs	feet heights	10, 20, 25
Areba	Kopfteil	tête de lit	headboard	140/160, 180/200

Alle Holzteile in Wildeiche natur, gebürstet, geölt | toutes les parties en bois en chêne nouveau naturel, brossé, huilé | all wooden parts in wildoak natural, brushed, oiled
9.68

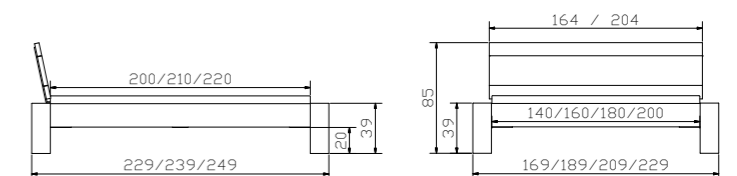



				Dimension cm
Cessa	Kommode	commode	chest of drawers	120/48/80
Placo anthracit	Deko (3er Set)	déco (set de 3)	deco (set of 3)	
Cubo	Nachttisch	table de nuit	bedside table	60/46/43
Smart black	Lampen (2er Set) 12V DC, 30 LED warm Energieeffizienzklasse A-A++	lampes (set de 2) 12V DC, 30 LED warm classe d'efficacité énergétique A-A++	lamps (set of 2) 12V DC, 30 LED warm energy efficiency class A-A++	

				Dimension cm
Bormio 18	Rahmen Breiten Längen	cadre largeurs longueurs	frame widths lengths	140, 160, 180, 200 200, 210, 220
Cobo anthracit	Füße Höhen	pieds hauteurs	feet heights	10, 20, 25
Sion Capa anthracit	Kopfteil Deko (2er Set)	tête de lit déco (set de 2)	headboard deco (set of 2)	140, 160, 180, 200

Alle Holzteile in Wildeiche coffee, gebürstet, geölt | toutes les parties en bois en chêne nouveau coffee, brossé, huilé | all wooden parts in wildoak coffee, brushed, oiled
9.70

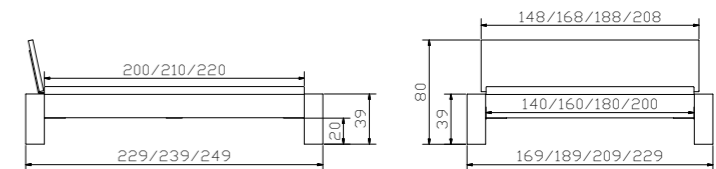





				Dimension cm
Osta	Nachttisch	table de nuit	bedside table	48/38/32

				Dimension cm
Cortina 18	Rahmen Breiten Längen	cadre largeurs longueurs	frame widths lengths	140, 160, 180, 200 200, 210, 220
Cobo	Füße Höhen	pieds hauteurs	feet heights	10, 20, 25
Sion	Kopfteil	tête de lit	headboard	140, 160, 180, 200
Sano	Kissen (2er Set) Campos blanc 372	coussins (set de 2) Campos blanc 372	cuhsions (set of 2) Campos blanc 372	55/4/35

Alle Holzteile in Wildeiche natur, gebürstet, geölt | toutes les parties en bois en chêne nouveau naturel, brossé, huilé | all wooden parts in wildoak natural, brushed, oiled
9.74

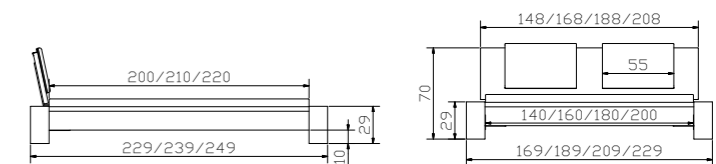



				Dimension cm
Cessa	Kommode	commode	chest of drawers	120/48/80
Placo anthracit	Deko (3er Set)	déco (set de 3)	deco (set of 3)	
Cubo	Nachttisch	table de nuit	bedside table	60/46/43

				Dimension cm
Cortina 18	Rahmen Breiten Längen	cadre largeurs longueurs	frame widths lengths	140, 160, 180, 200 200, 210, 220
Cobo anthracit	Füsse Höhen	pieds hauteurs	feet heights	10, 20, 25
Dorma	Kopfteil, Linen black 344	tête de lit, Linen black 344	headboard, Linen black 344	140, 160, 180, 200

Alle Holzteile in Wildeiche weiss, gebürstet, geölt | toutes les parties en bois en chêne nouveau blanc, brossé, huilé | all wooden parts in wildoak white, brushed, oiled
9.76

